



80x55xh80 cm



202 Kg



60x85xh92 cm 221 Kg



98x66xh90 cm 237 Kg



EP 460



1.8 kW / 2.4 Hp

**CUTS/MIN 98**

N°	1		2		3		4		5	
	mm	in	mm	in	mm	in	mm	in	mm	in
∅ R=650	<b>24</b>	0,94	<b>16</b>	0,63	<b>14</b>	0,55	<b>12</b>	0,47	<b>10</b>	0,39
∅ R=850	<b>20</b>	0,79	<b>14</b>	0,55	<b>12</b>	0,47	<b>10</b>	0,39	<b>10</b>	0,39

**DOTAZIONE OPTIONAL - OPTIONAL EQUIPMENT - EQUIPEMENT OPTIONAL - EQUIPAMIENTO OPCIONAL - WAHLWEISE AUSTRÜSTUNGEN**

	ITA	ENG	FRA	ESP	DEU
n.4	Ruote	Wheels	Roues	Ruedas	Räder

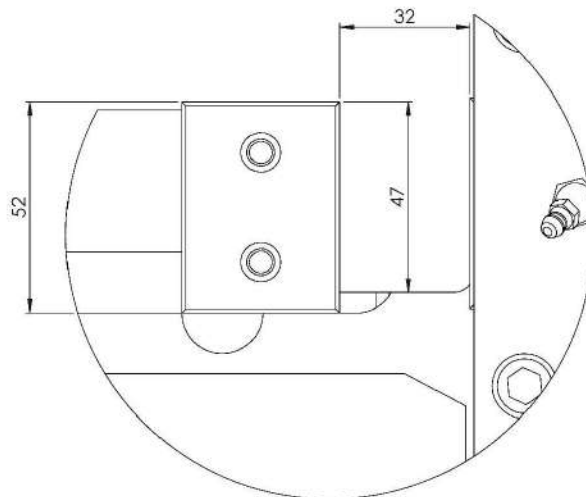

<b>Lato di taglio</b> Cutting edges Arêtes coupantes Aritas de corte Schneidkantn	<b>Durata taglio un lato</b> Duration of cutting edge durée de l'arête coupante Duraciòn arista de corte Lebensdauer Schneidkante	<b>Durata della lama</b> Duration of blade Durée de la lame Duraciòn cuchilla Lebensdauer Messer
<b>4</b>	<b>150 h</b>	<b>600 h</b>



80x55xh80 cm

202 Kg

60x85xh92 cm 212 Kg

98x66xh90 cm 228 Kg

EP 460

2,2 kW / 3 Hp

**CUTS/MIN 98**

N°	1		2		3		4		5	
	mm	in	mm	in	mm	in	mm	in	mm	in
∅ R=650	<b>26</b>	1,02	<b>18</b>	0,71	<b>14</b>	0,55	<b>12</b>	0,47	<b>10</b>	0,39
∅ R=850	<b>22</b>	0,87	<b>16</b>	0,63	<b>12</b>	0,47	<b>10</b>	0,39	<b>10</b>	0,39

**DOTAZIONE OPTIONAL - OPTIONAL EQUIPMENT - EQUIPEMENT OPTIONAL - EQUIPAMIENTO OPCIONAL - WAHLWEISE AUSTRÜSTUNGEN**

	ITA	ENG	FRA	ESP	DEU
n.4	Ruote	Wheels	Roues	Ruedas	Räder

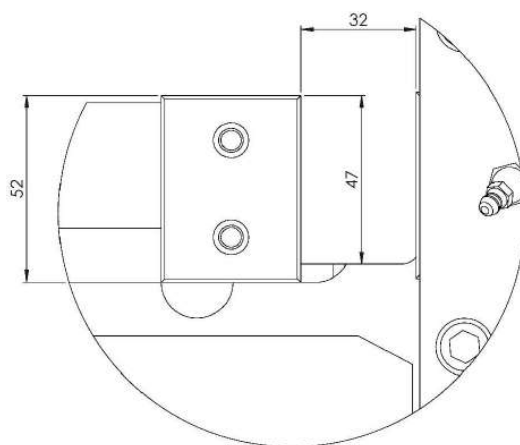



<b>Lato di taglio</b> Cutting edges Arêtes coupantes Aritas de corte Schneidkanten	<b>Durata taglio un lato</b> Duration of cutting edge durée de l'arête coupante Duraciòn arista de corte Lebensdauer Schneidkante	<b>Durata della lama</b> Duration of blade Durée de la lame Duraciòn cuchilla Lebensdauer Messer
<b>4</b>	<b>150 h</b>	<b>600 h</b>



 95x60xh87 cm

 293 Kg

 100x60xh98 cm 303 Kg

 96x64xh90 cm 319 Kg

 EP 460

 3 kW / 4 Hp

**CUTS/MIN** 94

N°	1		2		3		4		5	
	mm	in	mm	in	mm	in	mm	in	mm	in
∅ R=650	<b>32</b>	1,26	<b>22</b>	0,87	<b>16</b>	0,63	<b>12</b>	0,47	<b>10</b>	0,39
∅ R=850	<b>28</b>	1,10	<b>18</b>	0,71	<b>14</b>	0,55	<b>12</b>	0,47	<b>10</b>	0,39

**DOTAZIONE OPTIONAL - OPTIONAL EQUIPMENT - EQUIPEMENT OPTIONAL - EQUIPAMIENTO OPCIONAL - WAHLWEISE AUSTRÜSTUNGEN**

	ITA	ENG	FRA	ESP	DEU
n.4	Ruote	Wheels	Roues	Ruedas	Räder

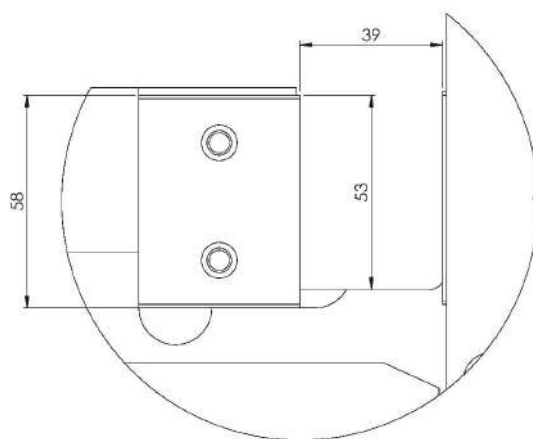



<b>Lato di taglio</b> Cutting edges Arêtes coupantes Aritas de corte Schneidkanten	<b>Durata taglio un lato</b> Duration of cutting edge durée de l'arête coupante Duraciòn arista de corte Lebensdauer Schneidkante	<b>Durata della lama</b> Duration of blade Durée de la lame Duraciòn cuchilla Lebensdauer Messer
<b>4</b>	<b>150 h</b>	<b>600 h</b>



 100x65xh92 cm

 405 Kg

 110x60xh88 cm 415 Kg

 117x73xh110 cm 431 Kg

 EP 460

 4 kW / 5.5 Hp

**CUTS/MIN 85**

N°	1		2		3		4		5	
	mm	in	mm	in	mm	in	mm	in	mm	in
∅ R=650	<b>36</b>	1,42	<b>24</b>	0,94	<b>18</b>	0,71	<b>14</b>	0,55	<b>12</b>	0,47
∅ R=850	<b>30</b>	1,18	<b>20</b>	0,79	<b>16</b>	0,63	<b>12</b>	0,47	<b>10</b>	0,39

**DOTAZIONE OPTIONAL - OPTIONAL EQUIPMENT - EQUIPEMENT OPTIONAL - EQUIPAMIENTO OPCIONAL - WAHLWEISE AUSTRÜSTUNGEN**

	ITA	ENG	FRA	ESP	DEU
n.4	Ruote	Wheels	Roues	Ruedas	Räder

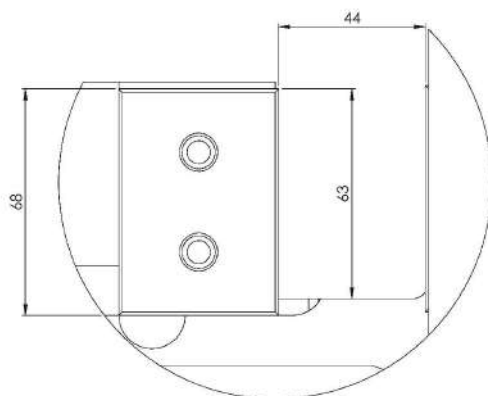

<b>Lato di taglio</b> Cutting edges Arêtes coupantes Aritas de corte Schneidkantn	<b>Durata taglio un lato</b> Duration of cutting edge durée de l'arête coupante Duraciòn arista de corte Lebensdauer Schneidkante	<b>Durata della lama</b> Duration of blade Durée de la lame Duraciòn cuchilla Lebensdauer Messer
<b>4</b>	<b>150 h</b>	<b>600 h</b>



110x60xh87 cm

540 Kg

70x130xh103 cm 562 Kg

73x117xh110 cm 564 Kg

EP 460

4 kW / 5.5 Hp

**CUTS/MIN** 51

N°	1		2		3		4		5	
	mm	in	mm	in	mm	in	mm	in	mm	in
∅ R=650	<b>40</b>	1,57	<b>28</b>	1,10	<b>22</b>	0,87	<b>16</b>	0,63	<b>14</b>	0,55
∅ R=850	<b>34</b>	1,34	<b>24</b>	0,94	<b>20</b>	0,79	<b>14</b>	0,55	<b>12</b>	0,47

**DOTAZIONE OPTIONAL - OPTIONAL EQUIPMENT - EQUIPEMENT OPTIONAL - EQUIPAMIENTO OPCIONAL - WAHLWEISE AUSRÜSTUNGEN**

	ITA	ENG	FRA	ESP	DEU
n.4	Ruote	Wheels	Roues	Ruedas	Räder

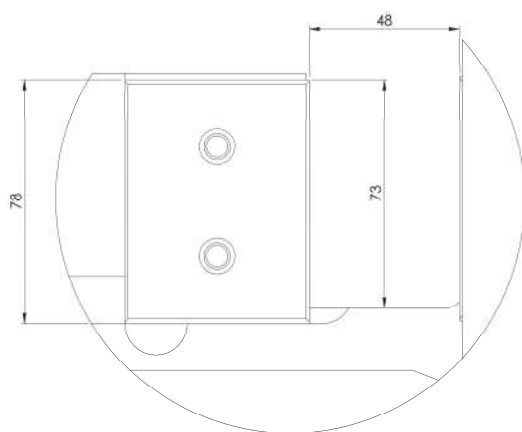

<b>Lato di taglio</b> Cutting edges Arêtes coupantes Aritas de corte Schneidkantn	<b>Durata taglio un lato</b> Duration of cutting edge durée de l'arête coupante Duraciòn arista de corte Lebensdauer Schneidkante	<b>Durata della lama</b> Duration of blade Durée de la lame Duraciòn cuchilla Lebensdauer Messer
<b>4</b>	<b>150 h</b>	<b>600 h</b>



125x65xh93 cm

600 Kg

145x90xh123 cm 629 Kg

153x93xh115 cm 643 Kg

EP 460

5.5 kW / 7.5 Hp

**CUTS/MIN** 42

N°	1		2		3		4		5	
	mm	in	mm	in	mm	in	mm	in	mm	in
∅ R=650	<b>46</b>	1,81	<b>32</b>	1,26	<b>26</b>	1,02	<b>22</b>	0,87	<b>18</b>	0,71
∅ R=850	<b>40</b>	1,57	<b>28</b>	1,10	<b>22</b>	0,87	<b>22</b>	0,87	<b>18</b>	0,71

**DOTAZIONE OPTIONAL - OPTIONAL EQUIPMENT - EQUIPEMENT OPTIONAL - EQUIPAMIENTO OPCIONAL - WAHLWEISE AUSRÜSTUNGEN**

	ITA	ENG	FRA	ESP	DEU
n.4	Ruote	Wheels	Roues	Ruedas	Räder

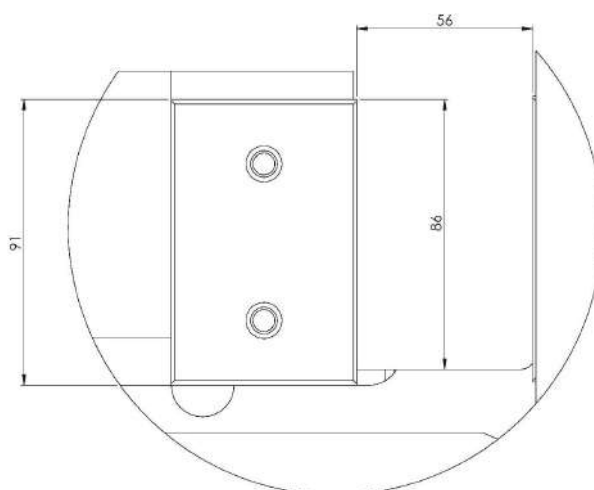

<b>Lato di taglio</b> Cutting edges Arêtes coupantes Aritas de corte Schneidkantn	<b>Durata taglio un lato</b> Duration of cutting edge durée de l'arête coupante Duraciòn arista de corte Lebensdauer Schneidkante	<b>Durata della lama</b> Duration of blade Durée de la lame Duraciòn cuchilla Lebensdauer Messer
<b>4</b>	<b>150 h</b>	<b>600 h</b>